

ZÁKLADNÍ ROZMĚRY
DIMENSION

česky
english

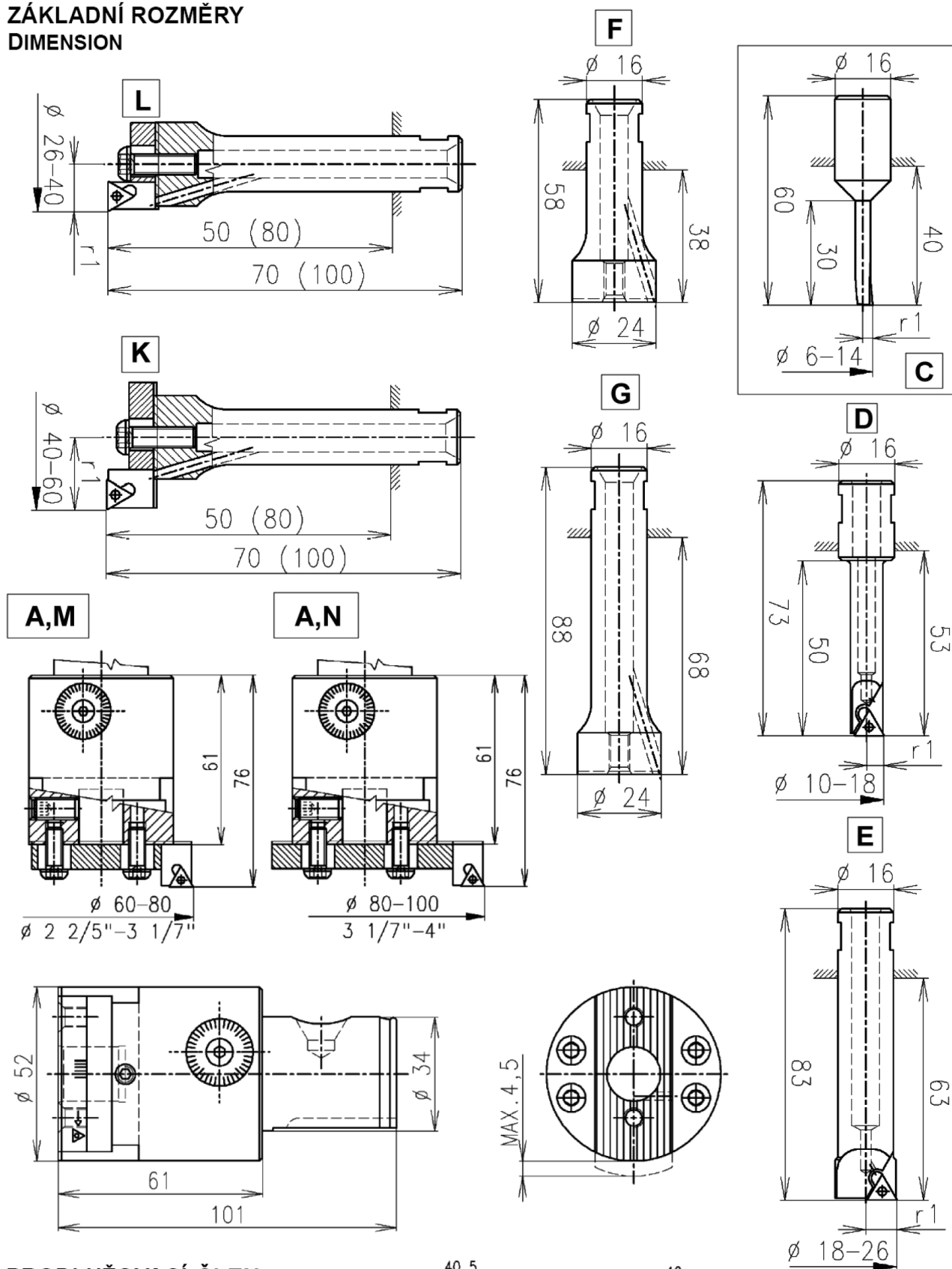

PRODLUŽOVACÍ ČLEN
EXTENSION ELEMENT

Kód Code	L [mm]
210 056	50
210 063	100
210 070	150

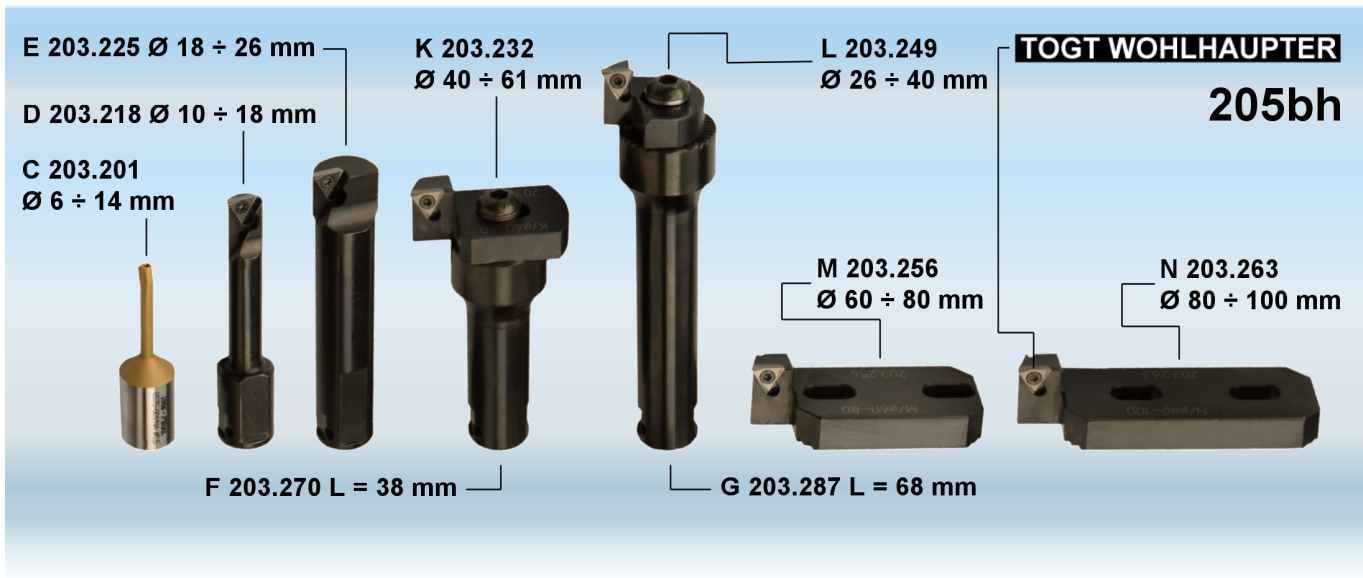

vyvrtávací nůž Ø 18 ÷ 26 mm E
boring tool Ø 18 ÷ 26 mm

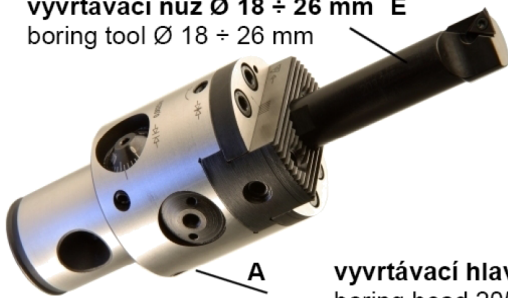

vyvrtávací hlava 205bh
boring head 205 bh

NAREX MTE™

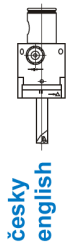

VÝMĚNNÉ BŘITOVÉ DESTIČKY TOGT--- EXCHANGEABLE INSERTS

Tvar 20 Form 20	Řezná destička se 3 břity Cutting tip with 3 edges				Karbíd Carbid				Cermet		Diamant Diamond				
	Úhel čela Angle face	Značení Marking	Objednávací číslo Order No.	nepovlakované uncoated		povlakované coated		nepovlakované uncoated		povlakované coated		CBN			PKD
				WHW01(K10)	WHW10(P10)	WHC10(Tin)	WHC25(Tin/Tic)	WHT12(WT112)	WHT20(WN120)	CBN C60	CBN C40	CBN C20	PKD D30		
	γ	r ₁													
	0,3	TOGW--03FN-11	097 150	•	•										
	1,0 5°	TOGT--01 FL-31	097 151		•	•									
	1,0 5°	TOGT--03 FL-31	097 152	•	•	•									
	1,0 13°	TOGT--01 FL-31	097 153	•											
	1,0 13°	TOGT--03 FL-31	097 154	•											
	0,4 5°	TOGT--01 FL-31	097 181	•	•	•									
	0,9 10°	TOGT--02 EL-31	097 546					•	•						
	0,9 10°	TOGT--01 FL-31	097 547					•	•						
	0,9 10°	TOGT--04 EL-31	097 599					•							
		TOGW--02 FN-71	097 487												•
		TOGW--03 TN-71	097 407									•	•	•	